

# +22dBm LoRaWAN Module with built-in MCU

## LM502

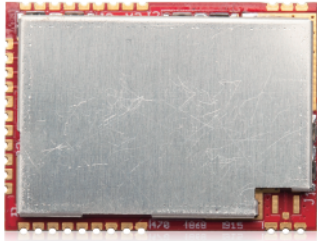

## OVERVIEW:

The LM502 is a general LoRa Wireless Communication module, with integrated LoRa Radio Transceiver, [SX1262 LoRa Modem](#) and a [32-Bit RISC MCU CY8C4147AXI-S445](#) from Cypress. The MCU uses [ARM Cortex M0+](#), with 48MHz operation frequency. The LoRa Radio Transceiver has continuous frequency coverage from 150MHz to 960MHz. The LoRa Modem supports LoRa modulation for LPWAN use cases and (G)FSK modulation for legacy use cases.

LM502 use the newest LoRa Modem SX1262 which provide high transmit power for ultra long range, ultra low power communication for LPWAN application.

LM502 can achieve a [high sensitivity of over -140dBm](#) and the maximum transmit power is [higher than +21dBm](#). This makes it suitable to be used in long range LPWAN and have high efficiency.

LM502 is provided with ready to use LoRaWAN Modem software. Developers only need to use AT Commands to control the module so to join the LoRaWAN network.

The LM502 also includes programmable and reconfigurable analog and digital blocks with flexible automatic routing. Developer can use the rich I/Os to connect to their sensors and provide a low cost / low power consumption / small size LoRaWAN End Node solution.

The LM502 demo board is a breakout board with LM502 pre-load. The demo board provides a rapid way to user to evaluate the feature of LM502. The demo board can be powered by 12v DC or USB port. The USB port of LM502 demo kit will be shown as one program port and one CDC port in computer, the program port is for flash firmware and CDC port is for serial access to LM502.

## Features:

- Small footprint: 20 x 27.5 x 2.5 mm.
- 48-MHz ARM Cortex-M0+ CPU
- LoRa Radio and LoRa Modem via SX1262
- 8-Channel DMA engine.
- LoRaWAN 1.0.3 protocol
- Embedded 12-bit 1Msps SAR ADC.
- SPI, 1xI2C, 2xUART, 1xSWD
- 3xADC, 1xCOMP.
- LoRa™ Modem
- Preamble detection
- Baud rate configurable
- FSK, GFSK, MSK and GMSK modulation
- Open source software design
- Available Band:433/868/915/920 Mhz
- External Antenna via I-Pex connector
- Low power consumption

# +22dBm LoRaWAN Module with built-in MCU

## Pin Definition

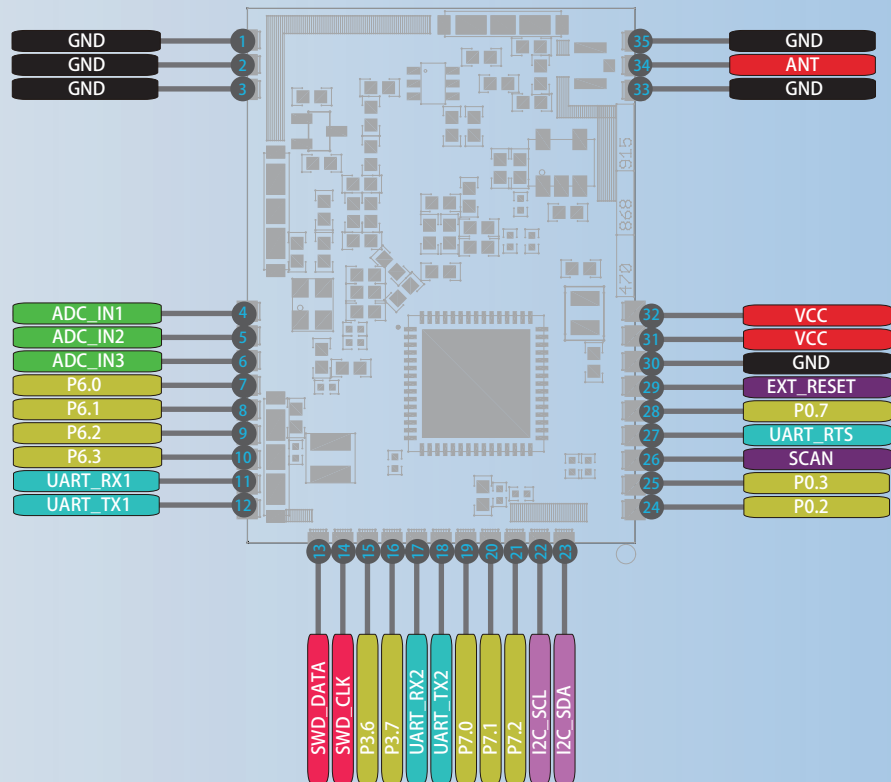

## Specifications:

### MCU Side:

- MCU: CY8C4147AXI-S445
- ARM Cortex-M0+
- Flash: 128KB
- SRAM: 16KB
- Clock Speed: 48Mhz

### Absolute Maximum Ratings:

- VCC: -0.3 ~ 3.9v
- Operating Temperature: -40 ~ 85°C
- I/O pins: -0.3v ~ 3.9v
- RF Input Power: +10dBm

### LoRa Side:

- LoRa Chip: sx1262
- 170 dB maximum link budget
- Max +22 dBm - 100 mW constant RF output
- Low RX current of 4.6 mA
- Programmable bit rate up to 62.5 kbps LoRa and 300 kbps FSK.
- High sensitivity: down to -140 dBm.
- Built-in bit synchronizer for clock recovery
- Automatic Channel Activity Detection (CAD) with ultra-fast AFC
- High Stability TCXO oscillator

### Common DC Characteristics:

- Supply Voltage: 1.8 ~ 3.7v
- Operating Temperature: -40 ~ 85°C
- I/O pins: Input High: > 0.7x VDD, Input Low: <0.3 x VCC

## Applications:

- Wireless Alarm and Security Systems
- Home and Building Automation
- Automated Meter Reading
- Industrial Monitoring and Control
- Long range Irrigation Systems, etc.

## Dimensions:

- Size: 20 x 27.5 x 2.5 mm
- Net Weight: 5g

## Order Info:

- LM502-XXXXX
  - LM502-demo-board-XXXXX
- XXXXX: Frequency Bands, options:  
EU433, CN470, EU868, IN865, KR920  
AS923, AU915, US915